

Arkansas Council of Teachers of Mathematics  
2014 State Exam  
Algebra I

For questions 1 through 25, mark your answer choice on the answer sheet provided. After completing items 1 through 25, answer each of the tiebreaker items in sequential order (do #1 first, followed by #2, and then #3 last). Be sure that your name is printed on each of the tiebreakers.

1. A store sells  $N$  refrigerators at a price of  $x$  dollars and then discounts the product and sells  $M$  of the same refrigerators at a price of  $y$  dollars. What quantity does the following expression represent?

$$\frac{xN + yM}{N + M}$$

- A. The number of refrigerators sold  
B. The revenue of the store  
C. The average number of the refrigerators sold  
D. The average price of the refrigerators sold
2. A team of painters is hired to paint two houses of different sizes. It takes a team twice the time to paint the larger house than it takes the team to paint the smaller house. If a quarter of the team can paint the smaller house in 16 hours, how long does it take the whole team to paint both houses?
- A. 8 hours  
B. 10 hours  
C. 12 hours  
D. 16 hours
3. Michael drove at an average speed of 65 mph from Boston to New York and then he drove 60 mph from New York to Washington. If the distance between Boston and New York is about 200 miles and the distance between New York and Washington is about 220 miles, what was the total amount of time it took Michael to travel from Boston to Washington? Give your answer to the nearest minute.
- A. 7 hours  
B. 6 hours and 50 minutes  
C. 6 hours and 30 minutes  
D. 6 hours and 45 minutes
4. A gas station sells  $m$  gallons of gasoline at \$3.80 per gallon and  $n$  gallons of diesel at \$4.25 per gallon.  
Write an equation relating  $m$  and  $n$  if the gas station sells fuel worth \$23,250.
- A.  $3.8m + 4.25n = 23,250$   
B.  $m + n = 23,250$   
C.  $4.25m + 3.8n = 23,250$   
D.  $(3.8 + 4.25)(m + n) = 23,250$

Arkansas Council of Teachers of Mathematics  
2014 Algebra I State Contest

5. The formula for the kinetic energy of a moving object is:

$$E_c = \frac{m \cdot v^2}{2}$$

Solve this formula for  $m$ .

- A.  $m = \frac{E_c}{2 \cdot v^2}$   
B.  $m = \frac{2 \cdot E_c}{v^2}$   
C.  $m = \frac{2 \cdot E_c}{v}$   
D.  $m = \frac{v^2}{2 \cdot E_c}$
6. Identify any maxima, minima, and zeroes of  $f(x) = -x^2 + 9$ .
- A. Maximum at  $y = 9$  when  $x = 0$   
Zeroes at  $x = -3, x = 3$   
B. Minimum at  $y = -9$  when  $x = 0$   
Zeroes at  $x = -3, x = 3$   
C. Maximum at  $y = 9$  when  $x = 0$   
Zeroes at  $x = 9, x = -9$   
D. Maximum at  $y = -9$  when  $x = 0$   
Zeroes at  $x = 9, x = -9$
7. Identify the intervals where the graph is increasing and decreasing.

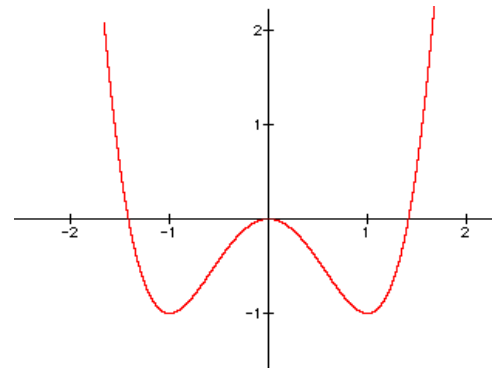

- A. Decreasing on the intervals  $(-\infty, -1)$  and  $(0, 1)$   
Increasing on the intervals  $(-1, 0)$  and  $(1, \infty)$   
B. Decreasing on the intervals  $(-1, 0)$  and  $(1, \infty)$   
Increasing on the intervals  $(-\infty, -1)$  and  $(0, 1)$   
C. Decreasing on the intervals  $(-\infty, -1)$  and  $(1, \infty)$   
Increasing on the intervals  $(-1, 0)$  and  $(0, 1)$   
D. Decreasing on the intervals  $(-1, 0)$  and  $(0, 1)$   
Increasing on the intervals  $(-\infty, -1)$  and  $(1, \infty)$
8. The function  $f(x) = 50 - 16x^2$  represents the height from the ground of an object  $x$  seconds after it is dropped from a height of 50 feet. Which of the following represents the same relationship for an object dropped from a height of 75 feet?
- A.  $y = f\left(\frac{3}{2}x\right)$   
B.  $y = \frac{3}{2}f(x)$   
C.  $y = f(x+25)$   
D.  $y = f(x)+25$

Arkansas Council of Teachers of Mathematics  
2014 Algebra I State Contest

**Use the following prompt for questions 9 and 10:**

Julie's grandfather gave her a dollar one day. Each day after that, he gave her twice as many dollars as he had given her on the previous day. Let  $f(n)$  represent the number of dollars Julie's grandfather gave her on day  $n$ , where the first day she receives a dollar is  $n = 1$ .

9. Which function models this situation?
- A.  $f(n) = 2^{n-1}$
  - B.  $f(n) = 2n$
  - C.  $f(n) = 2^{n+1}$
  - D.  $f(n) = (n - 1)^2$
10. How much money will Julie receive on the 12<sup>th</sup> day?
- A. \$24
  - B. \$121
  - C. \$2,048
  - D. \$8,192

11. Mr. Madison gave his students this pattern of white tiles:

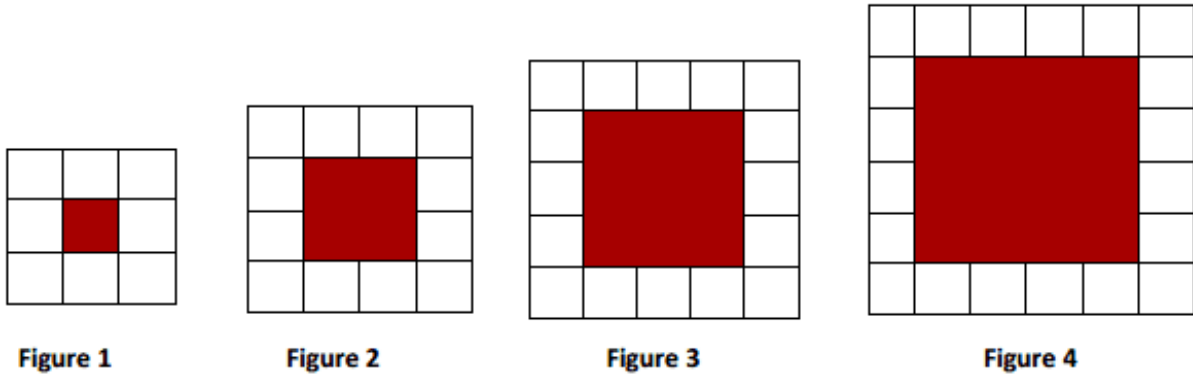

He asked his students to write an equation to represent the number of white tiles,  $t$ , for any figure number,  $n$ . Which equation represents the number of white tiles in the pattern?

- A.  $t = 4n + 8$       B.  $t = 4n + 4$       C.  $t = n + 4$       D.  $t = n + 2$

12. The table below represents the distance in feet that an aircraft has traveled at a constant speed in  $t$  seconds. What is the rate of change of the flight?

Time (sec)	6	9	30	42	54
Distance (feet)	6	7	14	18	22

- A.  $\frac{1}{3}$       B.  $\frac{4}{3}$       C. 3      D. 4

Arkansas Council of Teachers of Mathematics  
2014 Algebra I State Contest

13. Matthew purchased his dad's Ford Mustang for \$1500. He gave his dad \$500 for a down payment and then pays him \$100 per month. Which recursive rule describes the total amount paid on the vehicle after  $n$  months?

- A.  $\begin{cases} a_0 = 500 \\ a_n = a_{n-1} + 100, n > 0 \end{cases}$
- B.  $\begin{cases} a_0 = 100 \\ a_n = a_{n-1} + 500, n > 0 \end{cases}$
- C.  $\begin{cases} a_0 = 500 \\ a_n = a_{n-1} + 500, n > 0 \end{cases}$
- D.  $\begin{cases} a_0 = 100 \\ a_n = a_{n-1} + 100, n > 0 \end{cases}$

14. Consider the table below.

**Functions Table**

Characteristic	$f(x)$
Domain	All real numbers
Range	$y > 1$
Intercept	$(0, 2)$
Asymptote	$y = 1$
As $x$ approaches $+\infty$	$y$ approaches $+\infty$
As $x$ approaches $-\infty$	$y$ approaches 1

Which function has characteristics described in this table?

- A.  $f(x) = 2^x$
- B.  $f(x) = -2^x$
- C.  $f(x) = 3^x + 1$
- D.  $f(x) = -3^x + 1$

15. Which of the following shows  $9t^2 + 12t + 4$  factored completely?

- A.  $(3t + 2)^2$
- B.  $(3t + 4)(3t + 1)$
- C.  $(9t + 4)(t + 1)$
- D.  $9t^2 + 12t + 4$

Arkansas Council of Teachers of Mathematics  
2014 Algebra I State Contest

16. Consider the diagram below.

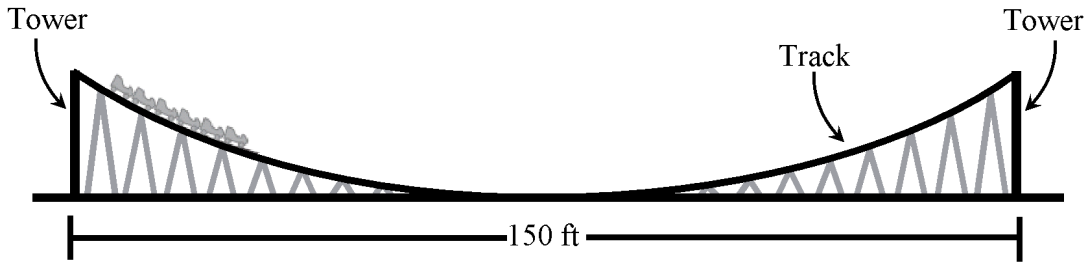

The function  $h(x) = \frac{1}{98}x^2$  describes  $h(x)$ , the height of part of a roller coaster track,

where  $x$  is the horizontal distance in feet from the center of this section of the track. The towers that support this part of the track are the same height and are 150 feet apart. Which is the best estimate of the height of the towers?

- A. 57.4 feet  
B. 85.7 feet  
C. 121.2 feet  
D. 229.6 feet
17. The cost to rent a construction crane is \$750 per day plus \$250 per hour of use. What is the maximum number of hours the crane can be used each day if the rental cost is not to exceed \$2500 per day?
- A. 2.5  
B. 3.7  
C. 7.0  
D. 13.0
18. Solve the following equation for  $p$ ,  $\frac{m-1}{p+3} = m + 1$
- A.  $p = \frac{2m-4}{m-1}$   
B.  $p = \frac{-2m-4}{m+1}$   
C.  $p = \frac{m+1}{-2m-4}$   
D.  $p = \frac{m-1}{2m-4}$
19. Which of the following are the points of intersection of the circle  $x^2 + y^2 = 20$  and the line  $y = 2x$ ?
- A. (2,4) and (-2,-4)  
B. (2,-4) and (-2,4)  
C. (4,2) and (-4,-2)  
D. (4,-2) and (-4,2)

Arkansas Council of Teachers of Mathematics  
2014 Algebra I State Contest

20. Which is a factor of  $a^4 - y^4$ ?

- A.  $a - y$
- B.  $a + y$
- C.  $a^2 + y^2$
- D. All of the above

21. Sue is asked to find the average number of moons per planet.

Her work is shown below.

1)  $0 + 0 + 1 + 2 + 39 + 31 + 21 + 8 + 1 = 103$

2)  $\frac{103}{8} \approx 12.88$

Did Sue make a mistake?

- A. There is a mistake at line 1
- B. There is a mistake at line 2
- C. There is a mistake at line 1 and 2
- D. No mistake

Planet	Known Moons
Mercury	0
Venus	0
Earth	1
Mars	2
Jupiter	39
Saturn	30
Uranus	21
Neptune	8

22. The graph below represents the data collected for the Sales of Hummers and Barrels of Gasoline in thousands for the year of 2011

From this graph we can see there is....

- A. A strong positive correlation between the sales of Hummers and Barrels of Gasoline
- B. A weak negative correlation between the sales of Hummers and Barrels of Gasoline
- C. A strong negative correlation between the sales of Hummers and Barrels of Gasoline
- D. No correlation between the sales of Hummers and Barrels of Gasoline

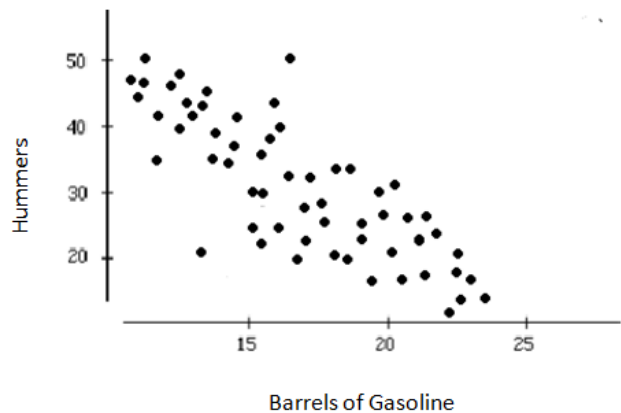

Arkansas Council of Teachers of Mathematics  
2014 Algebra I State Contest

23. Using the given data, a student is asked to find the first quartile, median, and third quartile.

22 17 22 49 55 21 49 62 21 16 18 44 42 48 40 33 45

Which of the following is the correct answer for this data?

- A. First quartile: 21  
Median: 40  
Third Quartile: 48.5
- B. First quartile: 14  
Median: 35  
Third Quartile: 40
- C. First quartile: 21  
Median: 20  
Third Quartile: 45
- D. First quartile: 16  
Median: 40  
Third Quartile: 70

24. Refer to the box & whisker graphs below that show the average monthly high temperatures for Milwaukee, Wisconsin & Honolulu, Hawaii.

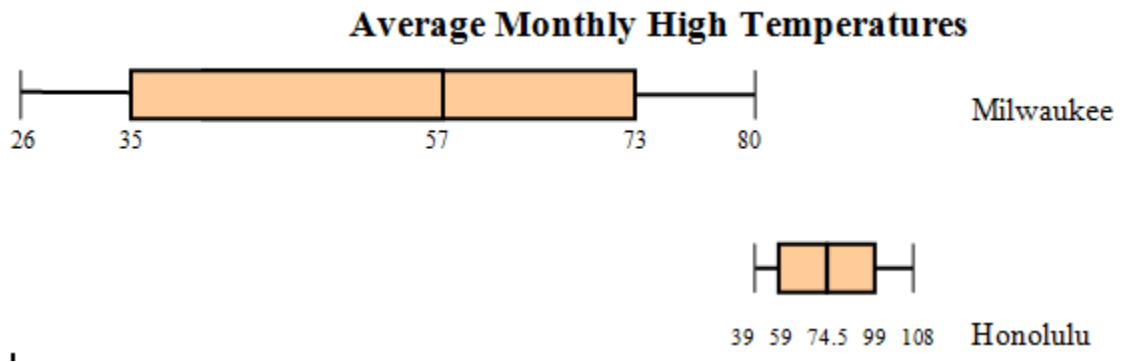

Which of the following statements is true about the Inner Quartile Range (IQR) of Honolulu and Milwaukee?

- A. The IQR of Honolulu is less than the IQR of Milwaukee
- B. The IQR of Honolulu is four more than the IQR of Milwaukee
- C. The IQR of Honolulu is equal to the IQR of Milwaukee
- D. The IQR of Honolulu is greater than the IQR of Milwaukee

Arkansas Council of Teachers of Mathematics  
2014 Algebra I State Contest

25. The table below shows the average hourly earnings of U.S. production workers for the selected years.

Year, $x$	1960	1965	1970	1975	1980	1985	1990	1995	2000
Earnings, $y$	\$2.09	\$2.46	\$3.23	\$4.53	\$6.66	\$8.57	\$10.01	\$11.43	\$13.24

Which of the following correctly represents the linear regression equation, the correlation coefficient, and the predicted average hourly earnings for 2010? Round to the nearest hundredth.

- A. Linear Regression:  $y = 0.30x - 581.21$   
Correlation Coefficient: 0.99  
Predictive Average Hourly Earnings: \$21.79
- B. Linear Regression:  $y = 0.45x - 639.4$   
Correlation Coefficient: -0.78  
Predictive Average Hourly Earnings: \$15.55
- C. Linear Regression:  $y = 1.95x + 2.39$   
Correlation Coefficient: 0.65  
Predictive Average Hourly Earnings: \$14.89
- D. Linear Regression:  $y = 0.29x + 1.39$   
Correlation Coefficient: 0.97  
Predictive Average Hourly Earnings: \$16.89



Arkansas Council of Teachers of Mathematics  
2014 Algebra I State Contest

Name: \_\_\_\_\_

Tie-Breaker 1

E.coli bacteria reproduce by division. Every 30 minutes, one E.coli cell divides into two cells. A new E.coli culture is started with 1 cell.

- A. Complete the following table where  $x$  represents each 30 minute time interval the cells divide and  $y$  represents the number of cells after each division.

<b>X</b>	0	1									
<b>Y</b>											

- B. Find a function that models the number of E.coli cells at the end of each 30-minute interval. \_\_\_\_\_

Arkansas Council of Teachers of Mathematics  
2014 Algebra I State Contest

Name: \_\_\_\_\_

Tie-Breaker 2

Trish earns a yearly salary of \$35,000 as a first year teacher. For each additional year employed, she earns \$500 more.

Hunter earns \$13.00 per hour as a new employee at the bank. Each year he receives a 2% cost of living increase.

- A. Write an equation to model Trish's annual salary for  $n$  number of years employed.
  
- B. Write an equation to model Hunter's income based on 40 hours per week for  $n$  number of years employed. Assume he works 52 weeks per year.
  
- C. After how many  $n$  years is Hunter's income exceed Trish's?

Arkansas Council of Teachers of Mathematics  
2014 Algebra I State Contest

Name: \_\_\_\_\_

Tie-Breaker 3

Use the following diagrams to answer the following questions.

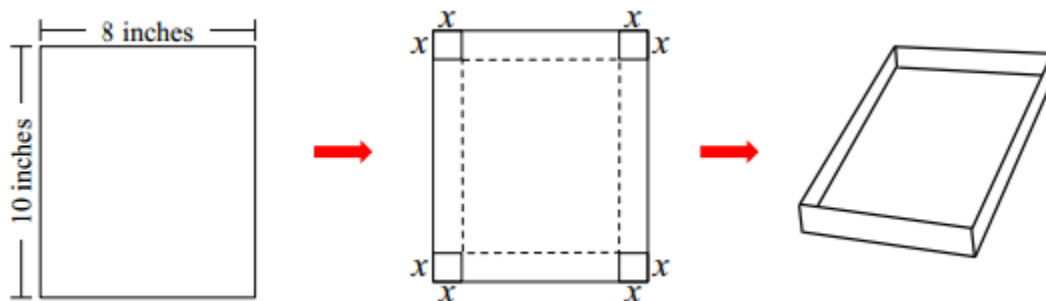

By cutting four equal squares out of a piece of paper, folding on the dotted lines shown in the diagram, and taping the corners, an open rectangular box can be created.

- A. Write an equation that relates the volume of the box ( $V$ ) to the side length of the cut-out squares ( $x$ ).

$V(x) =$

- B. In the context of the problem state the domain and range. Explain your reasoning or show your work in the spaced provided.

Arkansas Council of Teachers of Mathematics  
2014 Algebra I State Contest

Key:

1. D
2. C
3. D
4. A
5. B
6. A
7. A
8. D
9. A
10. C
11. B
12. A
13. A
14. C
15. A
16. A
17. C
18. B
19. A
20. D
21. A
22. C
23. A
24. D
25. A

Arkansas Council of Teachers of Mathematics  
2014 Algebra I State Contest

Tie Breakers:

1.

A.

<b>X</b>	0	1	2	3	4	5	6	7	8	9	10
<b>Y</b>	1	2	4	8	16	32	64	128	256	512	1024

B.  $f(x) = e^{\ln 2 \cdot t} = 2^t$

2.

A.  $f(n) = 35000 + 500n$

B.  $g(n) = 27040(1.02)^n$

C. 32.082 years

3.

A)  $f(x) = x(8 - 2x)(10 - 2x) = 4x^3 - 36x^2 + 80x$

B. Domain: (0,4)

Range: (0, 52.5)